

## Stirring technology

### ATEX stand stirrer SRW 100



## planetroll® ATEX stand stirrer SRW 100 for laboratory and pilot plant applications

### The decisive advantages

- The planetroll® ATEX stand stirrer SRW 100 is applicable in the ATEX zone 1 and 2 without monitoring system
- Smooth-running manual stroke adjustment due to counterweight inside lifting column
- A further ease of operation is offered by the stroke height locking device which can be operated single-handed by clamping mechanism
- Quick-action chuck for an easy stirrer shaft mounting without using any additional tools

### The properties

- The ATEX stand stirrer SRW 100 is developed specifically for laboratories and pilot plant stations
- The fields of application extend from a viscosity range of low- to high-viscosity products
- Different stirring elements and stirring shafts allow the use of various container sizes for your individual stirring tasks
- Speed adjustment by means of hand wheel with integrated scale<sup>①</sup> for the reproducibility of defined output speeds

### The special technology

- planetroll® variable-speed gearboxes for your optimal stirring result speed adjustment as well as the speed adaption for changes in viscosity
- Highest starting torques from stirring shaft speed zero
- Infinitely variable speed adjustment from and to zero speed with maximum torque
- The stand alignment is realized by adjustable feet
- Easily operated container clamping (optionally) ensures a central alignment of the stirred container to the stirring element

① Indicated scale value does not correspond to real stirring shaft speed

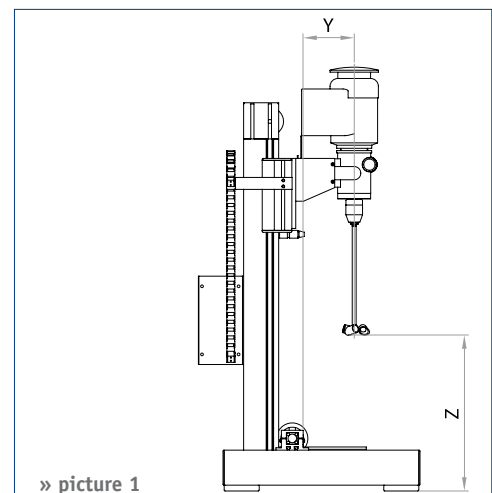

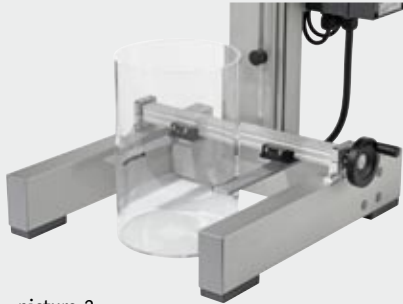

## ATEX EXECUTION

Technical data		Stand stirrer SRW 100 with planetroll® variable-speed gearbox plaromaster® MR	
Driving power	P [kW]	0.18 / 0.25 / 0.37 / 0.55	
Operating voltage	U [V]	400	
Rotational speed variable		Yes, mechanically by hand wheel	
Rotational speed range approx.	n [rpm]	0 – 390 / 0 – 600 / 0 – 1200 (depending on motor design)	
ATEX zone		Ex II 2G (zone 1) Ex II 3G (zone 2)	
ATEX temperature class		T3 / T4	
Stirred container	Diameter approx. mm	② min. 60 / ② max. 280 (further container diameters on request)	
Stirring shaft	Diameter approx.	10	
	Length approx.	300	
Outreach	③ y mm	140	
Stroke	③ z mm	400	
Weight approx.	m [kg]	min. 45 / max. 60	
Options		<p>Container clamping</p>  <p>» picture 2</p>	<p>Height-adjustable carrier for laboratory clamps on stand column</p> <p>(no picture)</p>

All dimensions correspond to the standard design, further dimensions on request

② The minimum distance for circulation on all sides between stirring element and stirred container wall is 25 mm  
 ③ Dimension see picture 1

Note: Despite thorough examination of the data, we cannot accept liability for any errors or omissions. Data is subject to change.

